

BACnet® IP Controller
PEC Series

INSTALLATION GUIDE



Reference

The Installation should be carried out by an electrician.

WARNING:

1. Disconnect power outage before installation and maintenance to prevent electrical shock.
2. Read instruction carefully, failure to follow instruction will damage the product or cause a hazardous condition.
3. The controller must be installed in the standard electric box and get power from class 2 transformer.
4. All wiring must comply with national and local electrical code regulations.
5. Check the nominal parameter of the controller with the installation guide and make sure the controller is suitable.
6. Overload protection is recommended for the primary side of the transformer.
7. Ensure the security of the device physical connection, only authorized user can get access to the device and its service.
8. Ensure the device network as well as associated upper layer server to be deployed and maintained in such a manner complied with group security policy, please refer to the user instruction of upper level server for detail description.
9. Ensure a safe and secure network environment isolated from external connection for the device.
10. Ensure secure deployment of router in the network, system enforcement and regular maintenance. Please refer to router security configuration manual.

Environmental

Storage Temperature	-40°C ~ 65.5°C
Operation Temperature	0°C ~ 50°C
Humidity	5%RH ~ 95%RH, Non condensation.
IP	IP20
Pollution Degree	2

Model Number

Model	Type	UI	DI	AO	DO
PEC8445-PB1-SM	Universal	8	4	4	5
PEC8445-PB1-SO	Universal	8	4	4	5

Electrical:

Voltage	24VAC, 50/60Hz
Power Consumption	5VA MAX. (Controller Only) 15VA MAX. (Controller including input, output and communication)

Hazardous Substances and Content of the Product

Parts	Hazardous substances					
	Pb	Hg	Cd	Cr (VI)	PBB	PBDE
Plastic parts	O	O	O	O	O	O
Terminal	X	O	O	O	O	O
PCBA	X	O	O	O	O	O

This table is based on SJ/T 11364.

O: The hazardous substances content in the related part are less than the limit in GB/T 26572 standard.

X: The hazardous substances content in the related part are more than the limit in GB/T 26572 standard.

*Other parts all conform to China RoHS requirements.

Package includes the following

- Controller 1 Set
- Installation guide 1 Pcs

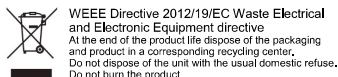

WEEE Directive 2012/19/EC Waste Electrical and Electronic Equipment directive
At the end of the product life dispose of the packaging and product in a corresponding recycling center. Do not dispose of the unit with the usual domestic refuse. Do not burn the product.

UI Voltage Input (Block F Blue)

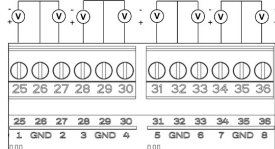

UI Dry Contact input (Block F Blue)

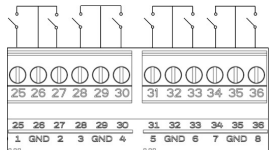

DI Digital Input (Block G, Yellow)

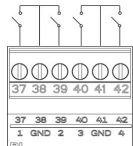

- Wiring Note:**
1. Communication Ethernet: Standard RJ45 and CAT5E or higher.
 2. Communication 485: Recommended to use 18-22AWG shielded twisted pair wire solid or stranded copper wire, strip length 7-8mm insulation, terminal screw torque 0.5Nm
 3. Sylk, AO, DO, UI, DI: Recommended to use 18-22AWG wire solid or stranded copper wire, strip length 7-8mm insulation, terminal screw torque 0.5Nm.

485 LED Status

485 LED status	485 Status
Solid off	No Extension module is configured or config file is broken
Solid off, blinking on once in 2.5 sec	Controller is running, no communication with Extension module
Solid off, blinking on twice in 2.5 sec	Controller is running and communicating with Extension module
Solid off, blinking on thrice in 2.5 sec	Controller is running and there is file transfer in progress with Extension module.

STA LED Status

STA LED Status	Controller Status
Off	No power to processor, LED damaged, low voltage to board, first second of power up, or boot loader damaged.
On (green)	No sufficient power supply to start up, power supply being checked, this takes about 3.5 second and occurs on power up, reset and reflash.
Very Slow Blink-continuously blinks 1 second on, 1 second off.	Controller operating normally.
Slow Blink-continuously blinks 0.5 second on, 0.5 second off.	Controller alarm is active, controller in process of download, controller lost its configuration.
Medium Blink – continuously blinks 0.25 second on, 0.25 second off.	Controller is in boot loader (reflash) mode.

*LED in Red Blinking: Hardware damage

ETH LED Status

ETH LED Status	BACnet Status
Solid on (green)	The processor is not running, or the processor is dead.
Solid on, blinking off once in 2.5 sec	The bootloader is running in the processor, but there is no IP link.
Solid on, blinking off twice in 2.5 sec	The bootloader is running in the processor and there is a BACnet communication.
Solid on, blinking off thrice in 2.5 sec	The bootloader is running in the processor and there is BACnet communication data transfer in progress.
Solid off	There is no power, the processor is not running, or the processor is dead.
Solid off, blinking on once in 2.5 sec	Controller is running, no IP link.
Solid off, blinking on twice in 2.5 sec	Controller is running and there is a BACnet communication.
Solid off, blinking on thrice in 2.5 sec	Controller is running and there is a BACnet communication data transfer in progress.
Quick on and off blink.	The processor is not running, or the processor is dead.

Terminal Definition and Wiring

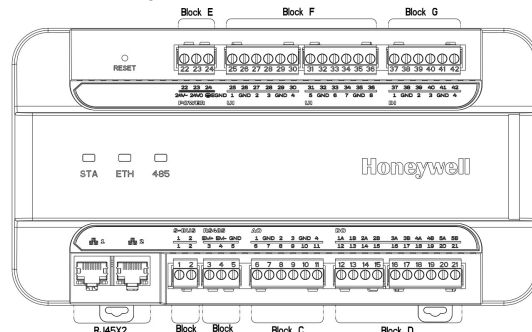

Communication Ethernet (RJ45)

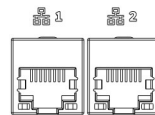

DO Digital Output (Block D Orange)

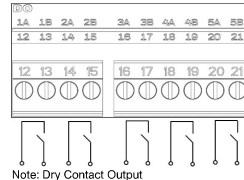

Sylk-Bus Block A Gray

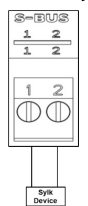

RS485 (Block B Gray)

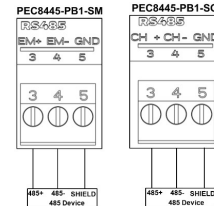

Power (Block E Black)

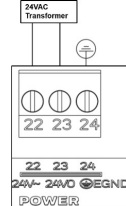

AO Analog Output (Block C Green)

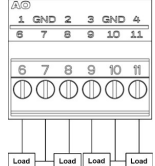

UI Resistance Input (Block F Blue)

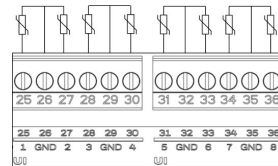

UI Voltage Input (Block F Blue)

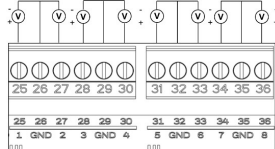

UI Dry Contact input (Block F Blue)

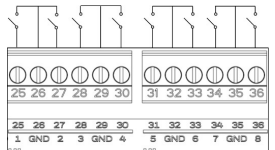

DI Digital Input (Block G, Yellow)

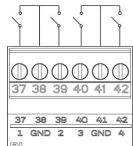

- Wiring Note:**
1. Communication Ethernet: Standard RJ45 and CAT5E or higher.
 2. Communication 485: Recommended to use 18-22AWG shielded twisted pair wire solid or stranded copper wire, strip length 7-8mm insulation, terminal screw torque 0.5Nm
 3. Sylk, AO, DO, UI, DI: Recommended to use 18-22AWG wire solid or stranded copper wire, strip length 7-8mm insulation, terminal screw torque 0.5Nm.

485 LED Status

485 LED status	485 Status
Solid off	No Extension module is configured or config file is broken
Solid off, blinking on once in 2.5 sec	Controller is running, no communication with Extension module
Solid off, blinking on twice in 2.5 sec	Controller is running and communicating with Extension module
Solid off, blinking on thrice in 2.5 sec	Controller is running and there is file transfer in progress with Extension module.

STA LED Status

STA LED Status	Controller Status
Off	No power to processor, LED damaged, low voltage to board, first second of power up, or boot loader damaged.
On (green)	No sufficient power supply to start up, power supply being checked, this takes about 3.5 second and occurs on power up, reset and reflash.
Very Slow Blink-continuously blinks 1 second on, 1 second off.	Controller operating normally.
Slow Blink-continuously blinks 0.5 second on, 0.5 second off.	Controller alarm is active, controller in process of download, controller lost its configuration.
Medium Blink – continuously blinks 0.25 second on, 0.25 second off.	Controller is in boot loader (reflash) mode.

*LED in Red Blinking: Hardware damage

ETH LED Status

ETH LED Status	BACnet Status
Solid on (green)	The processor is not running, or the processor is dead.
Solid on, blinking off once in 2.5 sec	The bootloader is running in the processor, but there is no IP link.
Solid on, blinking off twice in 2.5 sec	The bootloader is running in the processor and there is a BACnet communication.
Solid on, blinking off thrice in 2.5 sec	The bootloader is running in the processor and there is BACnet communication data transfer in progress.
Solid off	There is no power, the processor is not running, or the processor is dead.
Solid off, blinking on once in 2.5 sec	Controller is running, no IP link.
Solid off, blinking on twice in 2.5 sec	Controller is running and there is a BACnet communication.
Solid off, blinking on thrice in 2.5 sec	Controller is running and there is a BACnet communication data transfer in progress.
Quick on and off blink.	The processor is not running, or the processor is dead.

Dimensions (mm)

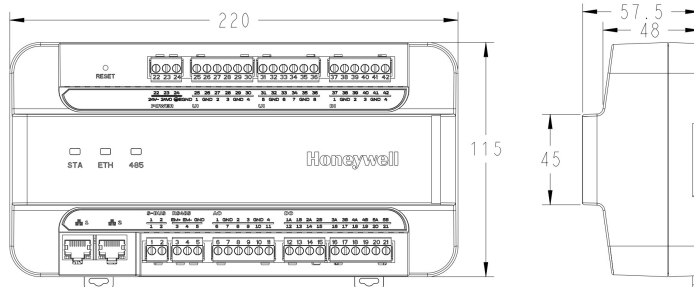

Mounting

Note:

- Removable terminal blocks are used for all wiring connections, which allow the controller to be wired before or after mounting;
- The controller must be mounted in a position that allows clearance for wiring, servicing, and removal;
- The controller mounts to DIN rail (standard EN50022 7.5mm x 35mm)

Installation:

1. Pull out the two rail hooks at the bottom of the controller, holding the controller with its top tilted in towards the DIN rail, hook the two top tabs on the back of the controller onto the top of the DIN rail.
2. Push the bottom of the controller and make sure the controller tightly attach on the DIN rail.
3. Push two rail hooks up and lock the controller.
4. Reset DIN rail hooks and lock the rail.

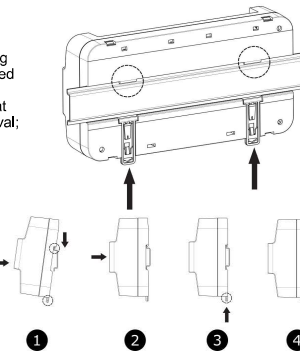

Honeywell Environmental and Combustion Controls (Tian Jin) Co., Ltd
No. 158, Nanhai Road
Tianjin, 300457, P.R.C.
Subject to change without notice.
Submit vulnerabilities via <https://www.honeywell.com/contact-us/vulnerability-reporting>