



# TC300 Thermostats

## CONNECTED DEVICE FOR COMMERCIAL BUILDINGS

### MOUNTING & INSTALLATION INSTRUCTIONS

#### INTRODUCTION

TC300 Thermostats are designed to be wall-mounted indoors. Mount in a clean, dry location away from windows, air ducts, and other places where environmental factors may affect temperature and humidity readings. If you mount the thermostat on the interior of an outside wall, thoroughly insulate it so the outside air behind the sensor does not affect the sensor reading.

There are 4 thermostat models available TC300B-G, TC300C-G, TC320B-G, and TC320C-G. All models share the same dimension hence the mounting procedure is same for all.

To meet the requirements of the Americans with Disabilities Act, mount no higher than 48" from the floor and with a minimum clear floor space of 30" X 48" (760 X 1220 mm).

#### Supported Documents

- TC300 Commercial Thermostats Datasheet (31-00645)
- TC300 Commercial Thermostats User Guide (31-00644)
- TC300 Commercial Thermostats Pocket guide (31-00648)
- TC300 Deco Plate Pocket guide (31-00657)
- TC300 BACnet Integration guide (31-00646)
- TC300 Safety Sheet (31-00643)

#### When installing this product

1. Read these instructions carefully. Failure to follow them could damage the product or cause a hazardous condition.
2. Check the ratings given in the instructions and marked on the product to make sure the product is suitable for your application.
3. Installer must be a trained, experienced service technician.
4. After installation is complete, check the product operation.
5. Be sure wiring complies with all applicable codes, ordinances, and regulations.

#### WARNING

**Electrical Shock Hazard.**

**Can cause severe injury, death or property damage.**

Disconnect the power supply before beginning installation to prevent electrical shock and equipment damage. More than one power supply may have to be disconnected.



#### MERCURY NOTICE

If this control is replacing a control that contains mercury in a sealed tube, do not place your old control in the trash. Dispose of it properly. Contact your local waste management authority for instructions regarding recycling and the proper disposal of an old control. If you have questions, contact Honeywell Customer Care Center.

#### Location

Do not install the Thermostat unit where it can be affected by:

- drafts or dead spots behind doors and in corners.
- hot or cold air from ducts.
- radiant heat from sun or appliances.
- concealed pipes and chimneys.
- unheated (uncooled) areas such as an outside wall behind the thermostat.

#### IMPORTANT

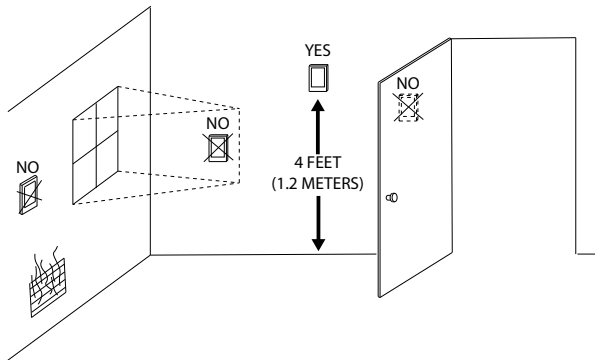
To avoid electrical interference, which can cause erratic performances, keep wiring runs as short as possible and do not run thermostat wires adjacent to the line voltage electrical distribution systems. Use shielded cable. The cable shield must be grounded only at the controlled equipment case.

#### USING ONBOARD TEMPERATURE SENSOR

Install the Thermostat about 4 ft. (1.2 m) above the floor in an area with good air circulation at average temperature. (See Fig. 1). Confirm mounting height meets Americans with Disabilities Act requirements.

**USING EXTERNAL TEMP./HUM. SENSORS**

When using the remote-mounted temperature (and humidity) sensor(s) to sense ambient conditions, install the Thermostat in an area that is accessible for setting and adjusting the temperature and settings.



**Fig. 1. Typical mounting location of the thermostat**

**WEEE**



**WEEE (Waste of Electrical and Electronic Equipment)**

- At the end of the product life, dispose of the packaging and product in an appropriate recycling center.
- Do not dispose of the device with the usual domestic refuse.
- Do not burn the device.

This symbol on our product shows a crossed-out “wheellie-bin” as required by law regarding the Waste of Electrical and Electronic Equipment (WEEE) disposal. This indicates your responsibility to contribute to saving the environment by proper disposal of this Waste i.e. Do not dispose of this product with your other wastes. To know the right disposal mechanism please check the applicable law.

**Regulation (EC) No 1907/2006**

According to Article 33 of Reach Regulation be informed that the substances listed below may be contained in these products above the threshold level of 0.1% by weight of the listed article.

| Product/Part Code                      | Substance Name | CAS Number |
|--|----------------|------------|
| Only TC300 thermostats main board PCBA | Lead           | 7439-92-1  |
|  | Lead oxide     | 1317-36-8  |

**Power supply guidelines and requirements**

**TC300B/TC320B (24 VAC)**

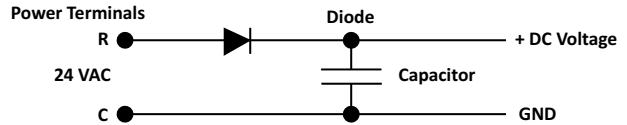
These thermostats use 24 VAC power from a UL Listed Class-2 24 VAC transformer (not provided in the kit). It also uses a half-wave rectifier to convert the AC power supply to

onboard power. This enables multiple devices with half-wave power supplies to be powered from a single, grounded transformer.

**! WARNING**

**Half wave devices and full wave devices must not use the same AC transformer.**

You must maintain wiring polarity. Failure to do so can result in equipment damage. If the HVAC equipment has an internal circuit board that is powered by the same transformer that will power the Thermostat, verify that it is NOT full wave.



**Fig. 2. Power terminals**

**IMPORTANT**

Use an UL Class 2 rated Transformer or a lesser capable transformer.

The 24 VAC secondary leads are not interchangeable. Once a lead connects to the GND terminal, it is the grounded lead. Observe and maintain polarity for subsequent connections. The GND terminal provides a reference ground for the circuit board and communications wiring. Use 18 AWG cable for best results.

**TC300C/TC320C**

These thermostats use line-voltage power transmitted by a power line, such as a cable, circuit, or conducting wire. Use the proper overload protection.

**Power supply wire sizing**

Long power supply wiring runs require selecting the wire gauge appropriately. If the wire gauge is inadequate the increased resistance and associated voltage drop may result in insufficient voltage supply to the Thermostat. The recommended wire gauge guidelines are as follows.

**Table 1. Power supply and wire sizing**

| SKU                   | Terminal    | Wire Gauge | Load   |
|-----------------------|-------------|------------|--------|
| TC300B-G/<br>TC320B-G | R, C        | 14-18 AWG  | 0-4 A  |
|                       | DO          | 14-26 AWG  | 0-1 A  |
|                       | Others      | 14-26 AWG  | N/A    |
| TC300C-G/<br>TC320C-G | L,N         | 14-18 AWG  | 0-10 A |
|                       | DO3-<br>DO5 | 14-20 AWG  | 0-3 A  |
|                       | DO1,<br>DO2 | 14-26 AWG  | 0-1 A  |
|                       | Others      | 14-26 AWG  | N/A    |

NOTE: The recommended wire gauge 14-26 AWG (0.2-1.5 mm<sup>2</sup> for solid or stranded, max 2.5 mm<sup>2</sup> for solid).

**FOR TC300B/TC320B (24 VAC)**

Min. Load = 4 VA (all DOs OFF, No Sylk sensor).

If the 14-18 AWG wire is used for R, C terminal,

Max. Load = 4 A, 96 VA (all DOs ON).

If the 20-22 AWG wire is used for R, C terminal

Max. Load = 3 A, 72 VA (all DOs ON).

If the 24-26 AWG wire is used for R, C terminal,

Max. Load = 2A, 48 VA (all DOs ON).

DO1, DO2, DO3, DIO1, and DIO2 all relay outputs are powered from the external transformer. The minimum load includes Thermostat and analog outputs at full load (Max. 10 V voltage output with 2 Kohms load).

Every relay output is N.O. (Normally Open) contacts with a maximum switch rating of 24 VAC @1 A (24 VA). The allowed maximum load is 96 VA, which assumes all 5 relay output loads are powered from the transformer. Actual power requirements depend on connected loads.

**FOR TC300C/TC320C**

Max. Load <= 10VA (Power Supply).

**! WARNING**

Ensure that for the B models thermostat power connections only use R and C terminals. COM should only be used for analog inputs/outputs. Failure to follow these instructions may result in thermostat operational and communication failures or equipment damage.

**Wiring the wallplate**

All wiring must comply with local electrical codes and ordinances. Supports 14-26 AWG (0.2-1.5 mm<sup>2</sup> for solid or stranded, max 2.5 mm<sup>2</sup> for solid) wires. Follow equipment manufacturer wiring instructions when available. A letter code is located near each terminal for identification.

**RS485 interface cable type**

One or two pairs (depending on the application) of twisted pairs complying with EIA485 standard (level IV, 22 AWG, solid core, non-shielded). e.g., J-Y-Y 2\*2\*0.8 or shielded wire.

An MSTP EIA-485 network shall use shielded twisted pair cable with a characteristic impedance between 100 and 130 ohms. Distributed capacitance between conductors

shall be less than 100 pF per meter (30 pF per foot). Distributed capacitance between conductors and shield shall be less than 200 pF per meter. A termination resistor of 120-130 ohms should be used at each end of the daisy chain as labelled R<sub>T</sub>.

**RS485 cabling arrangement**

**Shielded cable with twisted pair**

NOTES:

- To 24V version: Connect "C" to Ground.
- To line voltage version: Connect "COM" to Ground.

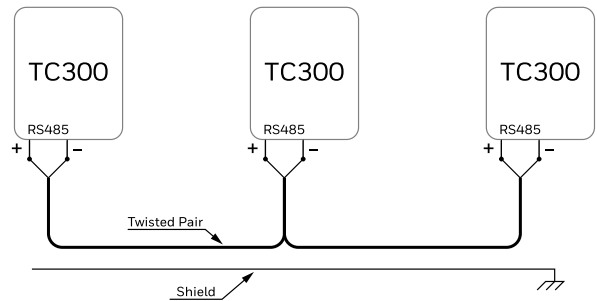
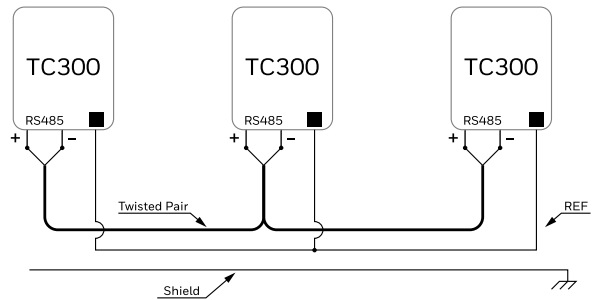


Fig. 3. RS485 Wiring

**Shielded cable with twisted pair and reference**

NOTES:

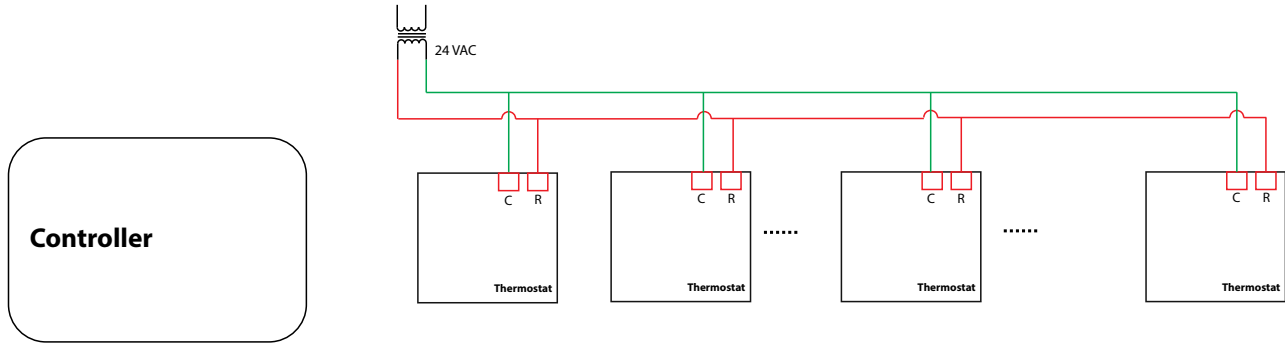
- To 24V version: Connect "C" to Reference.
- To line voltage version: Connect "COM" to Reference.



■ Terminal "C" for 24V  
Terminal "COM" for line voltage

Fig. 4. RS485 Wiring

**TC300 THERMOSTAT POWER WIRING**



**Fig. 5. TC300 thermostat power wiring**

If the controller shares the power transformer with TC300 thermostats, the connection style depends on the power design of controller and please consult the technical support to avoid short circuit.

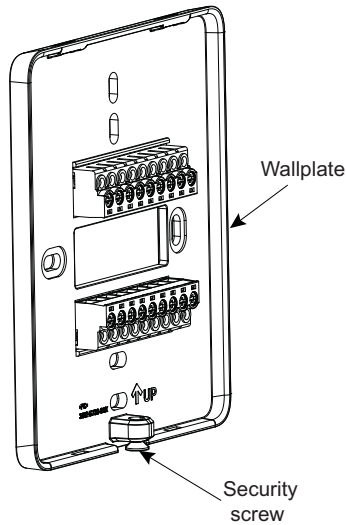
If TC300 thermostats are connected to a controller and share the transformer, please make sure the 24 VAC power wires are connected to the thermostats in the same sequence, as showed in the above figure. The green wire is connected to the C terminal and red wire is connected to the R terminal. Incorrect connection style can cause a short circuit.

## Mounting wallplate on the drywall

Mount the wallplate vertically on the wall. It supports 14–26 AWG (0.2–1.5 mm<sup>2</sup> for solid or stranded, max 2.5 mm<sup>2</sup> for solid) wires.

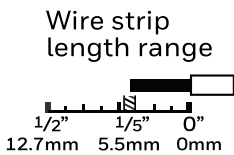
NOTE: If you are using a TC300 Deco plate for thermostat mounting, refer to the Deco plate pocket guide (31-00657) also.

1. At the bottom of the thermostat, loosen the Security screw using a screwdriver by turning it counterclockwise direction.

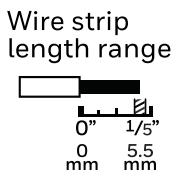


**Fig. 6. Loosen the security screw**

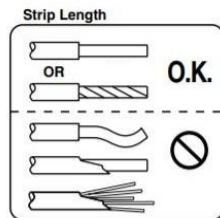
2. Before mounting the wallplate, make sure that the thermostat wires are stripped to the length marked on the wallplate.



### For B Models

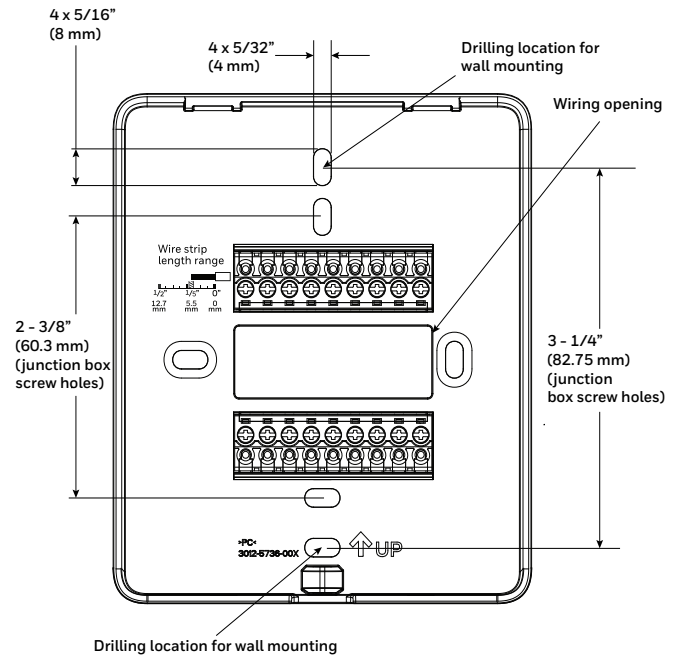


### For C Models



**Fig. 7. Wire strip length**

3. Position and level the wallplate along the wall and mark the drilling location using a pencil.



**Fig. 8. Wallplate drilling locations**

4. Remove the wallplate and drill two pilot holes on the wall, on the marks. For drywall, drill 3/16" (5 mm) holes. For firmer material such as plaster, drill 7/32" (6 mm) holes.
5. Gently tap anchors (provided in the kit) into the pilot holes until flush with the wall.
6. Pull the wires through the wiring opening of the wallplate and position the wallplate over the mounting holes. See Fig. 12 Wiring.
7. Insert the screws into the holes and tighten (screw torque 0.1 Nm).

## Mounting the wallplate on the junction box

TC300 thermostats can support vertical mounting of US 2"x4" junction box, vertical and horizontal mounting of 75\*75 mm, 86\*86 and European round(ø71 for German and ø75 for French) junction boxes.

NOTE: Use TC300 Deco plate for mounting if you are not using US 2"x4" or UK 75\*75 mm junction boxes. Refer to the Deco plate pocket guide (31-00657).

1. Install the junction box and perform the wiring as per its manufacturer's instructions.

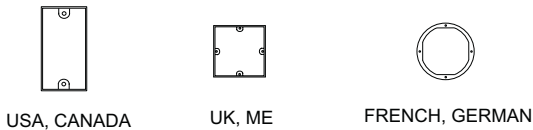


Fig. 9. Various junctions boxes

2. Before mounting the wallplate, make sure that the thermostat wires are stripped to the length marked on the wallplate.
3. Pull the wires through the wiring opening of the wallplate and position the wallplate along the junction box to align the mounting holes. For junction box screw holes, refer to Fig. 8.
4. Insert the screws into the holes and tighten them.

## Terminal layout TC300B/TC320B (24 VAC)

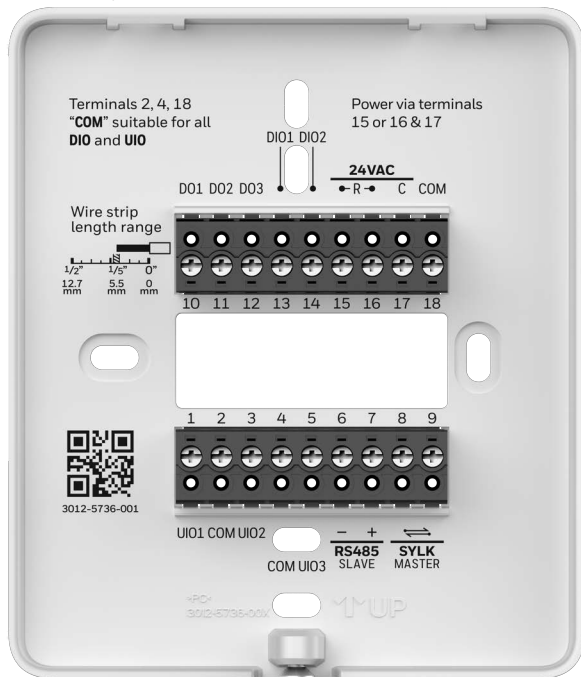


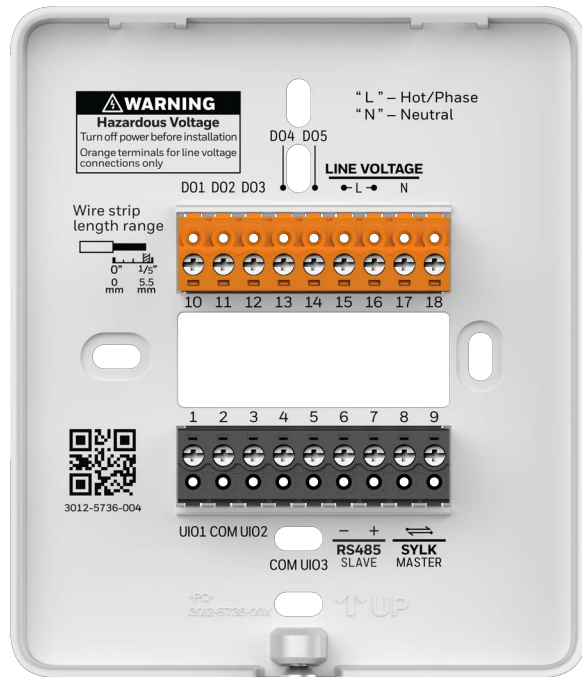
Fig. 10. Thermostat terminal assignments(TC300B/TC320-B)

Table 2. Terminal Identification

| Terminal Name | Terminal Number | Terminal Label | Description   |
|---------------|-----------------|----------------|---|
| UIO1          | 1               | UIO1           | Universal input/output                                    |
| COM           | 2               | COM            | Common  |
| UIO2          | 3               | UIO2           | Universal input/output                                    |
| COM           | 4               | COM            | Common  |
| UIO3          | 5               | UIO3           | Universal input/output                                    |
| RS485 SLAVE   | 6               | -              | BACnet/Modbus Communications                              |
| RS485 SLAVE   | 7               | +              | BACnet/Modbus Communications                              |
| SYLK MASTER   | 8               | ↔              | Sylk bus  |
| SYLK MASTER   | 9               | ↔              | Sylk bus  |
| DO1           | 10              | DO1            | Relay output  |
| DO2           | 11              | DO2            | Relay output  |
| DO3           | 12              | DO3            | Relay output  |
| DIO1          | 13              | DIO1           | Relay output<br>Analog input<br>Dry contact digital input |
| DIO2          | 14              | DIO2           | Relay output<br>Analog input<br>Dry contact digital input |
| 24 VAC POWER  | 15/16           | R              | 24 VAC power from Class2 transformer                      |
| 24 VAC POWER  | 17              | C              | 24 VAC common (Neutral) from Class2 transformer           |
| COM           | 18              | COM            | Common  |

**⚠ WARNING**  
Do NOT wire the thermostat to line voltage.

## Terminal layout TC300C-G/ TC320C-G



**Fig. 11. Thermostat terminal assignments (TC300C-G/TC320C-G)**

**Table 3. Terminal Identification**

| Terminal Name | Terminal Number | Terminal Label | Description                  |
|---------------|-----------------|----------------|------------------------------|
| UIO1          | 1               | UIO1           | Universal input/output       |
| COM           | 2               | COM            | Common                       |
| UIO2          | 3               | UIO2           | Universal input/output       |
| COM           | 4               | COM            | Common                       |
| UIO3          | 5               | UIO3           | Universal input/output       |
| RS485 SLAVE   | 6               | -              | BACnet/Modbus Communications |
| RS485 SLAVE   | 7               | +              | BACnet/Modbus Communications |
| SYLK MASTER   | 8               | ↔              | Sylk bus                     |
| SYLK MASTER   | 9               | ↔              | Sylk bus                     |

**Table 3. Terminal Identification (Continued)**

| Terminal Name          | Terminal Number | Terminal Label | Description  |
|------------------------|-----------------|----------------|--|
| DO1                    | 10              | DO1            | Relay output   |
| DO2                    | 11              | DO2            | Relay output   |
| DO3                    | 12              | DO3            | Relay output   |
| DO4                    | 13              | DO4            | Relay output   |
| DO5                    | 14              | DO5            | Relay output   |
| Line Voltage Hot/Phase | 15/16           | L              | Line - Line voltage power input TC300C-G/TC320C-G: 100-277 VAC |
| Line Voltage Neutral   | 17              | N              | Neutral - Line voltage power input                             |
| Not applicable         | 18              | NC             | Not connected  |

## Accessories ordering part numbers

**Table 4. Accessories Part Numbers**

|                  |                  |
|------------------|------------------|
| TRTC-DECOPLATE-1 | TC300 deco plate |
|------------------|------------------|

## Wiring the wallplate

### IMPORTANT

All wiring must comply with local electrical codes and ordinances.

NOTE: Supports 14-26 AWG (0.2-1.5 mm<sup>2</sup> for solid or stranded, max 2.5 mm<sup>2</sup> for solid) wires.

Follow equipment manufacturer wiring instructions when available. A letter code is located near each terminal for identification.



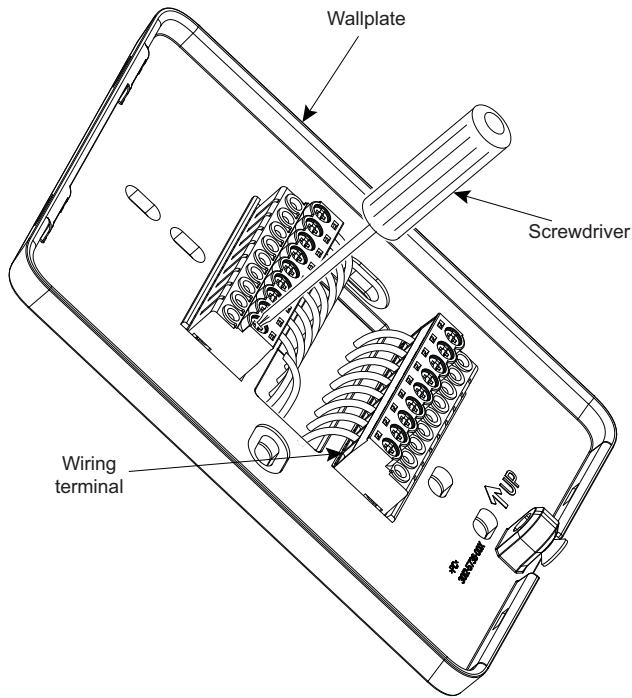
## CAUTION

**Power must not be connected while wiring.**

Wiring a unit that is powered may result in electrical shock and/or equipment damage.

1. Connect wires to the terminals. See Fig. 10 for terminal assignments and Table 2 for terminal descriptions.
2. Loosen the terminal screw, and insert the solid wire (twist if it is stranded) into the wiring terminal hole directly.

3. Tight the terminal screw using the Phillips screwdriver (screw torque 0.4 Nm).



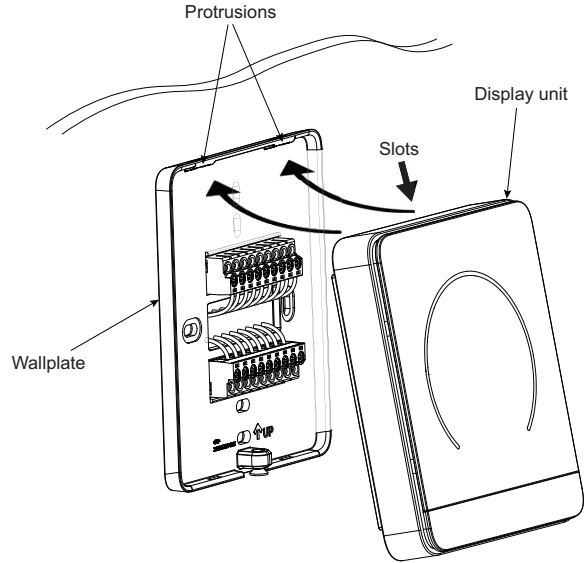
**Fig. 12. Wiring**

4. Push excess wire back into the hole.
5. Check for loose or frayed wire that may cause a short.

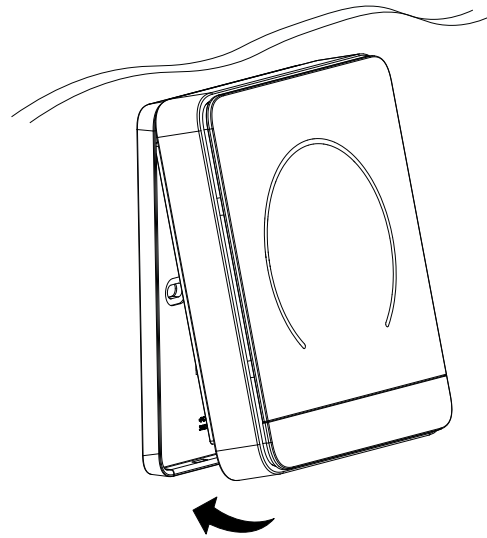
## Mounting the display unit

After all wiring is completed, install the display onto the wallplate.

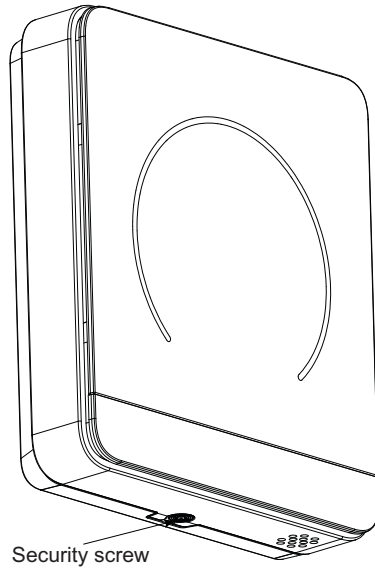
1. Hold the display unit in forward tilted position and align the slots in the display unit with the protrusions on top of the wall plate.



2. Carefully pivot the display onto the wall plate to ensure proper engagement of pins with terminal blocks while ensuring engagement of protrusions and slots is maintained as shown in step 1.



3. Gently tighten the Security screw using a screwdriver by turning it in the clockwise direction (screw torque 0.1 Nm).

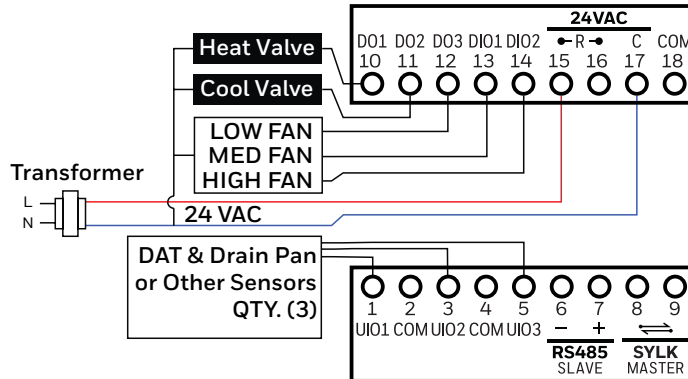


## Dismounting the display unit

1. Unscrew the security screw.
2. Detach the bottom side by pulling the display unit out and detach the top side.

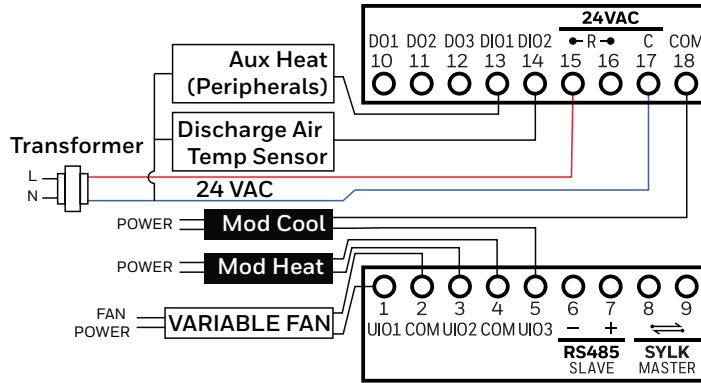
## TC300B/TC320B 24 V equipment terminal assignment

NOTE: L can be connected to 15 or 16, or it can be simultaneously connected to both 15 and 16.



**Fig. 13. 4-Pipe FCU, On/Off Valves, 3-Speed Fan**

NOTE: L can be connected to 15 or 16, or it can be simultaneously connected to both 15 and 16.



**Fig. 14. 4-Pipe FCU, Modulating Valves, Aux. Heat, Var. Speed Fan, Discharge Air Temp. Sensor**

**Table 5. FCU 4 Pipe Dual coil**

| Valve Type                      | Terminal Name and Number |                      |                        |  |                        |  |      |      |
|---------------------------------|--------------------------|----------------------|------------------------|--|------------------------|--|------|------|
|                                 | DO1                      | DO2                  | DO3                    | DIO1   | DIO2                   | UIO1   | UIO2 | UIO3 |
|                                 | 10                       | 11                   | 12                     | 13   | 14                     | 1  | 3    | 5    |
| On/off heat,<br>On/off cool     | *On/off heat             | *On/off heat         | Low fan                | Medium fan   | High fan/fan           | Variable fan   |      |      |
|                                 |                          |                      | Aux heat (peripherals) | Sensors: Discharge air temp. <sup>1</sup> & Drain pan or other |                        | Sensors: Discharge air temp. <sup>1</sup> & Drain pan or other |      |      |
| Floating heat,<br>Floating cool | *Floating heat open      | *Floating heat close | *Floating cool open    | *Floating cool close   | Single speed fan       | Variable fan   |      |      |
|                                 |                          |                      |                        |  | Aux heat (peripherals) | Sensors: Discharge air temp. <sup>1</sup> & Drain pan or other |      |      |

**Table 5. FCU 4 Pipe Dual coil (Continued)**

| Valve Type                       | Terminal Name and Number |            |              |  |      |  |                 |                 |
|----------------------------------|--------------------------|------------|--------------|--|------|--|-----------------|-----------------|
|                                  | DO1                      | DO2        | DO3          | DIO1   | DIO2 | UIO1   | UIO2            | UIO3            |
|                                  | 10                       | 11         | 12           | 13   | 14   | 1  | 3               | 5               |
| Modulating heat, Modulating cool | Low fan                  | Medium fan | High fan/fan | Aux heat (peripherals)   |      | Variable fan   | Modulating heat | Modulating cool |
|                                  |                          |            |              | Sensors: Discharge air temp. <sup>1</sup> & Drain pan or other |      | Sensors: Discharge air temp. <sup>1</sup> & Drain pan or other |                 |                 |

NOTES:

- \*Only the specified operation can be configured based on the valve type.
- <sup>1</sup>When configurable I/O is limited may substitute Syk discharge air sensor C7400S for analog sensor.

**Table 6. FCU 4 Pipe Single coil**

| Valve Type                         | Terminal Name and Number |                   |                        |  |              |  |  |  |
|------------------------------------|--------------------------|-------------------|------------------------|--|--------------|--|--|--|
|                                    | DO1                      | DO2               | DO3                    | DIO1   | DIO2         | UIO1   | UIO2   | UIO3   |
|                                    | 10                       | 11                | 12                     | 13   | 14           | 1  | 3  | 5  |
| On/off valve, Changeover valve     | *On/off valve            | Change-over valve | Low fan                | Medium fan   | High fan/fan | Variable fan   |  |  |
|                                    |                          |                   | Aux heat (peripherals) | Sensors: Discharge air temp. <sup>1</sup> & Drain pan or other |              | Sensors: Discharge air temp. <sup>1</sup> & Drain pan or other |  |  |
| Modulating valve, Changeover valve |                          | Change-over valve | Low fan                | Medium fan   | High fan/fan | Variable fan   | Modulating valve   |  |
|                                    |                          |                   | Aux heat (peripherals) | Sensors: Discharge air temp. <sup>1</sup> & Drain pan or other |              | Sensors: Discharge air temp. <sup>1</sup> & Drain pan or other |  | Sensors: Discharge air temp. <sup>1</sup> & Drain pan or other |
| 6-way valve                        | Low fan                  | Medium fan        | High fan/fan           | Aux heat (peripherals)   |              | 6-way valve  | Variable fan   |  |
|                                    |                          |                   |                        | Sensors: Discharge air temp. <sup>1</sup> & Drain pan or other |              |  | Sensors: Discharge air temp. <sup>1</sup> & Drain pan or other |  |

NOTES:

- \*Only the specified operation can be configured based on the valve type.
- <sup>1</sup>When configurable I/O is limited may substitute Syk discharge air sensor C7400S for analog sensor.

**Table 7. FCU 2 Pipe**

| Valve Type                          | Terminal Name and Number |                         |  |  |  |  |                  |             |
|-------------------------------------|--------------------------|-------------------------|--|--|--|--|------------------|-------------|
|                                     | DO1                      | DO2                     | DO3  | DIO1   | DIO2   | UIO1   | UIO2             | UIO3        |
|                                     | 10                       | 11                      | 12   | 13   | 14   | 1  | 3                | 5           |
| On/off valve                        | *On/off valve            | Aux heat (supplemental) | Low fan  | Medium fan   | High fan/fan   | Variable fan   |                  | Pipe sensor |
|                                     |                          |                         |  | Sensors: Discharge air temp. <sup>1</sup> & Drain pan or other |  | Sensors: Discharge air temp. <sup>1</sup> & Drain pan or other |                  |             |
| Modulating valve, Change-over valve |                          | Aux heat (Supplemental) | Low fan  | Medium fan   | High fan/fan   | Variable fan   | Modulating valve | Pipe sensor |
|                                     |                          |                         | Sensors: Discharge air temp. <sup>1</sup> & Drain pan or other |  | Sensors: Discharge air temp. <sup>1</sup> & Drain pan or other | Sensors: Discharge air temp. <sup>1</sup> & Drain pan or other |                  |             |
| Floating valve                      | *Floating valve open     | *Floating valve close   | Low fan  | Medium fan   | High fan/fan   | Variable fan   |                  | Pipe sensor |
|                                     |                          |                         | Aux heat (supplemental)  | Sensors: Discharge air temp. <sup>1</sup> & drain pan or other |  | Sensors: Discharge air temp. <sup>1</sup> & Drain pan or other |                  |             |

NOTES:

- \*Only the specified operation can be configured based on the valve type.
- <sup>1</sup>When configurable I/O is limited may substitute Sylk discharge air sensor C7400S for analog sensor.

**Table 8. Conventional**

| Valve Type | Terminal Name and Number |              |         |              |              |                  |      |      |
|------------|--------------------------|--------------|---------|--------------|--------------|------------------|------|------|
|            | DO1                      | DO2          | DO3     | DIO1         | DIO2         | UIO1             | UIO2 | UIO3 |
|            | 10                       | 11           | 12      | 13           | 14           | 1                | 3    | 5    |
| 1H1C       | Heat stage 1             | Cool stage 1 | Low fan |              | High fan/fan | Sensors (QTY. 3) |      |      |
|            |                          |              |         | Dehumidifier | Humidifier   |                  |      |      |
| 2H         | Heat stage 1             | Heat stage 2 | Low fan |              | High fan     | Sensors (QTY. 3) |      |      |
|            |                          |              |         | Dehumidifier | Humidifier   |                  |      |      |
| 2C         | Cool stage 1             | Cool stage 2 | Low fan |              | High fan     | Sensors (QTY. 3) |      |      |
|            |                          |              |         | Dehumidifier | Humidifier   |                  |      |      |
| Heat only  | Heat stage 1             |              | Low fan |              | High fan/fan | Sensors (QTY. 3) |      |      |
|            |                          |              |         | Dehumidifier | Humidifier   |                  |      |      |
| Cool only  |                          | Cool stage 1 | Low fan |              | High fan/fan | Sensors (QTY. 3) |      |      |
|            |                          |              |         | Dehumidifier | Humidifier   |                  |      |      |

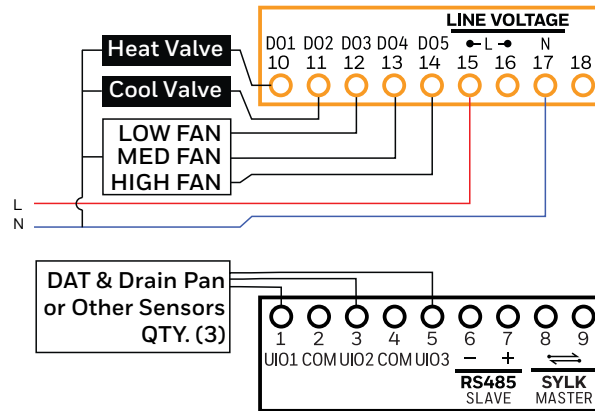
**Table 9. Heat pump**

| Valve Type   | Terminal Name and Number |                  |                         |              |              |                    |               |      |
|--------------|--------------------------|------------------|-------------------------|--------------|--------------|--------------------|---------------|------|
|              | DO1                      | DO2              | DO3                     | DIO1         | DIO2         | UIO1               | UIO2          | UIO3 |
|              | 10                       | 11               | 12                      | 13           | 14           | 1                  | 3             | 5    |
| Water source | *Heat /cool stage 1      | *Reversing valve | Water flow valve        | Low fan      | High fan/fan | Proof of waterflow | Other sensors |      |
|              |                          |                  | Aux heat (supplemental) | Dehumidifier | Humidifier   |                    |               |      |
| Air source   | *Heat /cool stage 1      | *Reversing valve | Low fan                 |              | High fan/fan | Outdoor air temp.  | Other sensors |      |
|              |                          |                  | Aux heat (supplemental) | Dehumidifier | Humidifier   |                    |               |      |

NOTE: \*Only the specified operation can be configured based on the valve type.

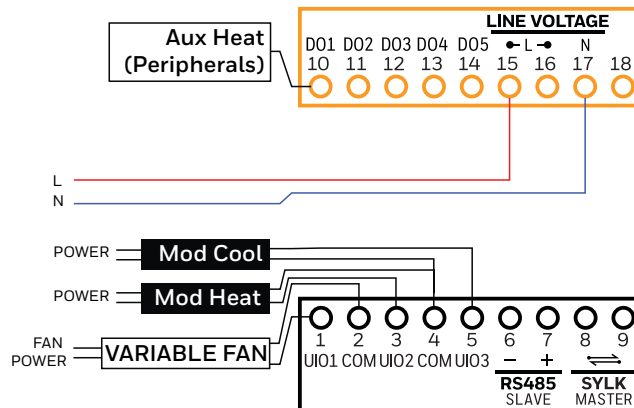
### TC300C/TC320C line voltage equipment terminal assignment

NOTE: L can be connected to 15 or 16, or it can be simultaneously connected to both 15 and 16.



**Fig. 15. 4-Pipe FCU, On/Off Valves, 3-Speed Fan**

NOTE: L can be connected to 15 or 16, or it can be simultaneously connected to both 15 and 16.



**Fig. 16. 4-Pipe FCU, Modulating Valves, Aux. Heat, Var. Speed Fan, Discharge Air Temp. Sensor**

**Table 10. FCU 4 Pipe dual coil**

| Valve Type                          | Terminal Name and Number |              |                        |            |              |  |                 |                 |
|-------------------------------------|--------------------------|--------------|------------------------|------------|--------------|--|-----------------|-----------------|
|                                     | DO1                      | DO2          | DO3                    | DO4        | DO5          | UIO1   | UIO2            | UIO3            |
|                                     | 10                       | 11           | 12                     | 13         | 14           | 1  | 3               | 5               |
| On/off heat,<br>On/off cool         | *On/off heat             | *On/off cool | Low fan                | Medium fan | High fan/fan | Variable fan   | Other sensors   |                 |
|                                     |                          |              | Aux heat (peripherals) |            |              | Sensors: Discharge air temp. <sup>1</sup> & Drain pan or other |                 |                 |
| Modulating heat,<br>Modulating cool |                          |              | Low fan                | Medium fan | High fan/fan | Variable fan   |                 |                 |
|                                     | Aux heat (peripherals)   |              |                        |            |              | Sensors: Discharge air temp. <sup>1</sup> & Drain pan or other | Modulating heat | Modulating cool |

NOTES:

- \*Only the specified operation can be configured based on the valve type.
- <sup>1</sup>When configurable I/O is limited may substitute Sylk discharge air sensor C7400S for analog sensor.

**Table 11. FCU 4 Pipe Single coil**

| Valve Type                            | Terminal Name and Number |                   |                        |            |  |  |  |      |
|---------------------------------------|--------------------------|-------------------|------------------------|------------|--|--|--|------|
|                                       | DO1                      | DO2               | DO3                    | DO4        | DO5  | UIO1   | UIO2   | UIO3 |
|                                       | 10                       | 11                | 12                     | 13         | 14   | 1  | 3  | 5    |
| On/off valve,<br>Changeover valve     | *On/off valve            | Change-over valve | Low fan                | Medium fan | High fan/fan   | Variable fan   |  |      |
|                                       |                          |                   | Aux heat (peripherals) |            |  | Sensors: Discharge air temp. <sup>1</sup> & Drain pan or other |  |      |
| Modulating valve,<br>Changeover valve |                          | Change-over valve | Low fan                | Medium fan | High fan/fan   | Variable fan   |  |      |
|                                       | Aux heat (peripherals)   |                   |                        |            | Sensors: Discharge air temp. <sup>1</sup> & Drain pan or other | Modulating valve   | Sensors: Discharge air temp. <sup>1</sup> & Drain pan or other |      |
| 6-way valve                           |                          |                   | Low fan                | Medium fan | High fan/fan   |  | Variable fan   |      |
|                                       | Aux heat (peripherals)   |                   |                        |            |  | 6-way valve  | Sensors: Discharge air temp. <sup>1</sup> & Drain pan or other |      |

NOTES:

- \*Only the specified operation can be configured based on the valve type.
- <sup>1</sup>When configurable I/O is limited may substitute Sylk discharge air sensor C7400S for analog sensor.

**Table 12. FCU 2 Pipe**

| Valve Type       | Terminal Name and Number |                         |                         |            |  |  |                  |             |
|------------------|--------------------------|-------------------------|-------------------------|------------|--|--|------------------|-------------|
|                  | DO1                      | DO2                     | DO3                     | DO4        | DO5  | UIO1   | UIO2             | UIO3        |
|                  | 10                       | 11                      | 12                      | 13         | 14   | 1  | 3                | 5           |
| On/off valve     | *On/off valve            |                         | Low fan                 | Medium fan | High fan/fan   | Variable fan   |                  | Pipe sensor |
|                  |                          |                         | Aux heat (supplemental) |            |  | Sensors: Discharge air temp. <sup>1</sup> & Drain pan or other |                  |             |
| Modulating valve |                          |                         | Low fan                 | Medium fan | High fan/fan   | Variable fan   | Modulating valve | Pipe sensor |
|                  |                          | Aux heat (supplemental) |                         |            | Sensors: Discharge air temp. <sup>1</sup> & Drain pan or other |  |                  |             |

NOTES:

- \*Only the specified operation can be configured based on the valve type.
- TC300C/TC320C line voltage doesn't support floating valve.
- <sup>1</sup>When configurable I/O is limited may substitute Sylk discharge air sensor C7400S for analog sensor

## Sylk sensor

NOTE: The below image is only for reference, for detailed information, see the Sylk sensor address table.

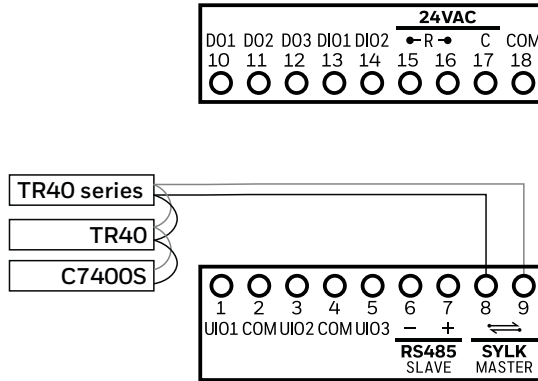


Fig. 17. Sylk sensor address detail

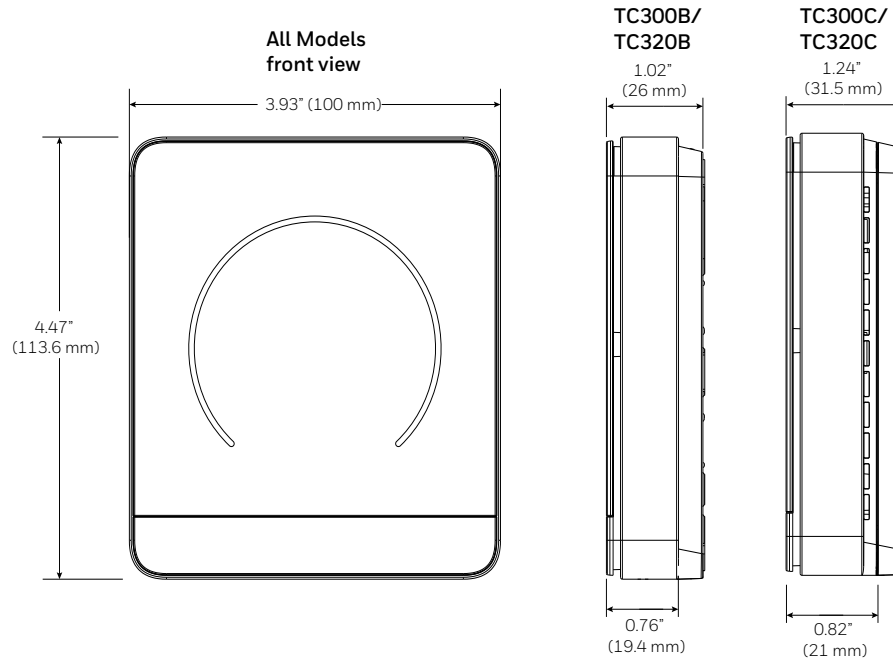
Table 13. Sylk device dip switches

| Sylk Address | Device Type                              | Sensors                                  | DIP Switches  |
|--------------|--|--|---|
| 2            | Sylk Temperature & Humidity & CO2 sensor | TR40<br>TR40-H<br>TR40-CO2<br>TR40-H-CO2 |   |
|              |  | TR50-3N<br>TR50-3D                       | <p>Note: Set the red colored switches to the position as shown in the above image</p> |
| 3            | Sylk Temperature sensor                  | TR40                                     |   |
| 4            | Sylk Temperature sensor                  | TR40                                     |   |
| 5            | Sylk Temperature sensor                  | TR40                                     |   |
| 8            | Outdoor Air Sensor                       | C7400S                                   |   |
| 10           | Discharge Air Sensor                     | C7400S                                   |   |

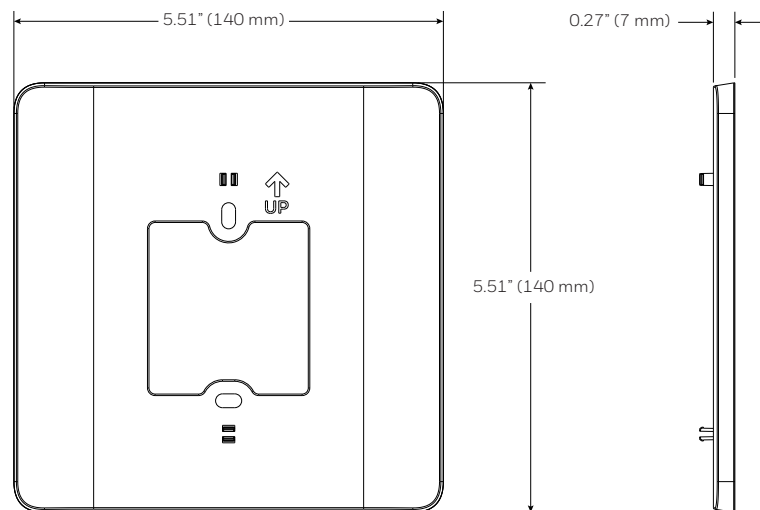
NOTE: When configurable I/O is limited may substitute the Sylk sensors for the discharge air, remote temperature, or outdoor air temperature.

# DIMENSIONS

## Thermostat



## TRTC-Decoplate-1



By using this Honeywell literature, you agree that Honeywell will have no liability for any damages arising out of your use or modification to, the literature. You will defend and indemnify Honeywell, its affiliates and subsidiaries, from and against any liability, cost, or damages, including attorneys' fees, arising out of, or resulting from, any modification to the literature by you.

**Honeywell | Building Automation**

715 Peachtree Street, N.E.,

Atlanta, Georgia, 30308,

United States.

<https://buildings.honeywell.com>

® U.S. Registered Trademark  
© 2025 Honeywell International Inc.  
31-00642-04 | Rev. 04-25

**Honeywell**